

PLAN

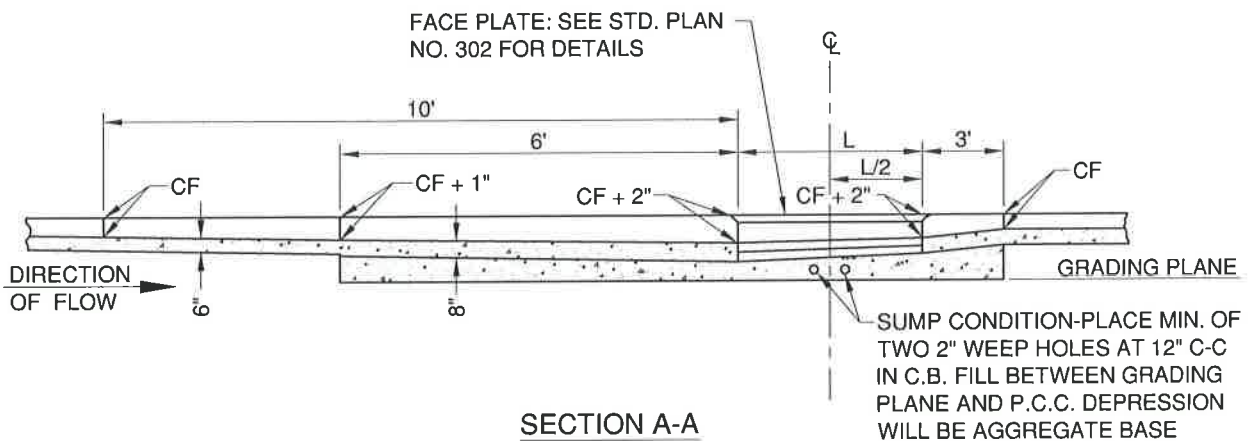

SECTION A-A

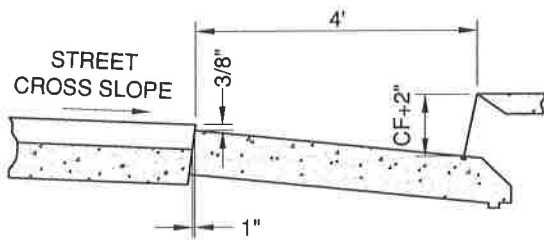

SECTION B-B

NOTES:

1. LOCAL DEPRESSION SHALL BE 520-C-2500 PORTLAND CEMENT CONCRETE, 8" THICK.
2. LOCAL DEPRESSION SHALL COMFORM TO SAME SHAPE WHETHER GRATE INLET OR CURB OPENING.
3. LENGTH OF OPENING "L" SHALL BE SPECIFIED ON PLANS.
4. BOTH ENDS OF DEPRESSION SHALL BE SYMMETRICAL ABOUT  $\bar{C}$  OF OPENING IN SUMP CONDITION.
5. SEE STD. PLAN NO. 302 FOR CURB OPENING DETAIL.

FOR 6" TO 8" CF TRANS. ELEVATION AT (b) BELOW T.C.	FOR 8" TO 10" CF TRANS. ELEVATION AT (b) BELOW T.C.
0.37'	0.54'

BASED ON 2.0% STREET CROSSFALL

APPROVED:

*Manu Joss*  
P.W. DIRECTOR / CITY ENGINEER



City of Westminster  
DEPARTMENT OF PUBLIC WORKS

REVISED DATE: 5/11/16

LOCAL DEPRESSION

STANDARD NUMBER

301