

PLAN

RIGHT-OF-WAY

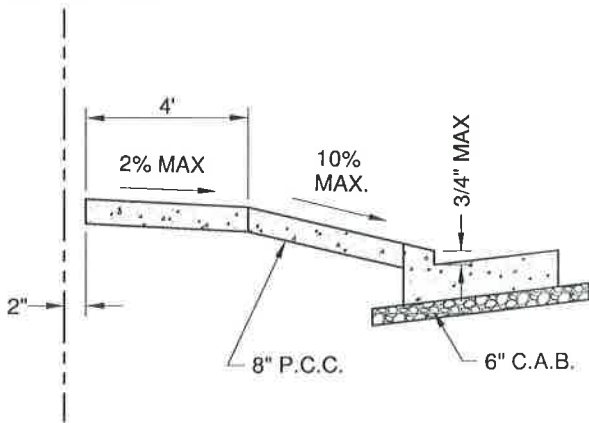

PROFILE

NOTES:

- CONCRETE SHALL BE CLASS 520-C-2500 WITH A MINIMUM THICKNESS OF 8".
1. W = 25' MIN. 30' MAX. W=30' ON ALL MAJOR AND PRIMARY ARTERIAL STREETS. WIDER W MAY BE REQUIRED BY THE CITY ENGINEER. CURB FACE ≤ 6"; X = 3' / CURB FACE > 6"; X = 4'.
  2. SEE STANDARD #201 FOR CURB AND GUTTER DETAIL.
  3. SEE STANDARD #203 FOR SIDEWALK DETAIL.
  4. MINIMUM OF 22' OF FULL HEIGHT CURB BETWEEN DRIVEWAY APPROACHES ON SAME PROPERTY WITH THE APPROVAL OF THE CITY ENGINEER.
  5. TOP OF "X" SHALL BE A MINIMUM OF 2' FROM PROPERTY LINES.
  6. DRIVEWAY APPROACH SHALL BE GIVEN A MEDIUM BROOM FINISH.
  7. DRIVEWAY APPROACH SHALL HAVE A MAXIMUM SLOPE OF 10%.
  8. EXISTING AC SHALL BE REMOVED BY SAWCUTTING AT A MINIMUM DISTANCE OF TWO FEET FROM LIP OF GUTTER.
  9. MINIMUM COMPACTION FOR SOIL UNDERNEATH DRIVEWAY APPROACH SHALL BE 90%.
  10. FOR PARKWAY LESS THAN 8' WIDE, A PUBLIC SIDEWALK EASEMENT MAY BE REQUIRED AT THE BACK OF PROPERTY R.O.W. LINE

APPROVED:

*William House*  
P.W. DIRECTOR / CITY ENGINEER



City of Westminster

DEPARTMENT OF PUBLIC WORKS

COMMERCIAL & INDUSTRIAL  
DRIVEWAY APPROACH

STANDARD NUMBER

209

REVISED DATE: 5/11/16