

* UNLESS WAIVED BY CITY ENGINEER

PLAN

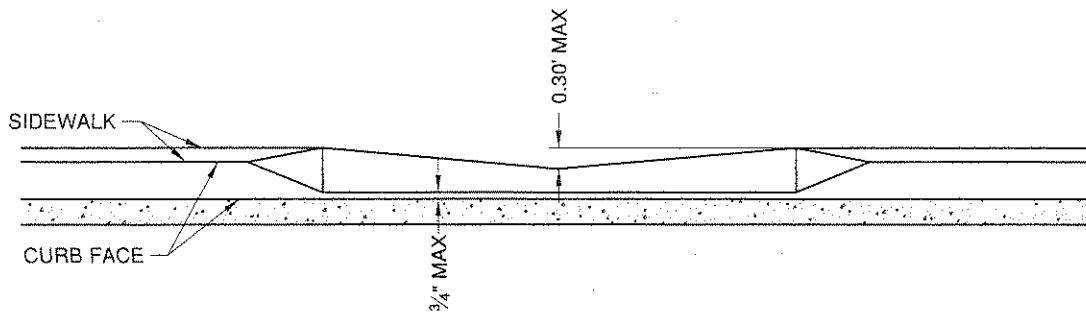

SECTION A-A

NOTES:

CONCRETE SHALL BE CLASS 520-C-2500 WITH A MINIMUM THICKNESS OF 8".

1. W = 30' MIN. ON ALL ARTERIAL STREETS.
CURB FACE ≤ 6"; X = 3' / CURB FACE > 6"; X = 4".
2. SEE STANDARD #201 FOR CURB AND GUTTER DETAIL.
3. SEE STANDARD #203 FOR SIDEWALK DETAIL.
4. MINIMUM OF 22' OF FULL HEIGHT CURB BETWEEN DRIVEWAY APPROACHES ON SAME PROPERTY WITH THE APPROVAL OF THE CITY ENGINEER.
5. TOP OF "X" SHALL BE A MINIMUM OF 2' FROM PROPERTY LINES AND 3' FROM ANY OBSTACLES (LIGHT POLES, POWER POLES, UTILITY BOXES, VAULTS, ETC.).
6. DRIVEWAY APPROACH SHALL BE GIVEN A MEDIUM BROOM FINISH.
7. DRIVEWAY APPROACH SHALL HAVE A MAXIMUM SLOPE OF 10%.
8. EXISTING AC SHALL BE REMOVED BY SAWCUTTING AT A MINIMUM DISTANCE OF TWO FEET FROM LIP OF GUTTER.
9. MINIMUM COMPACTION FOR SOIL UNDERNEATH DRIVEWAY APPROACH SHALL BE 90%.

APPROVED:

Maria V. Rousse
P.W. DIRECTOR / CITY ENGINEER



City of Westminster
DEPARTMENT OF PUBLIC WORKS

COMMERCIAL & INDUSTRIAL
DEPRESSED
DRIVEWAY APPROACH

STANDARD NUMBER

210

REVISED DATE: 5/15/08