

GENERAL NOTES:

1. UTILITY BOX SIZE AND MATERIAL SHALL BE PER UTILITY COMPANY STANDARDS. IF UTILITY BOXES ARE LOCATED IN THE SIDEWALK, REPLACE FULL WIDTH OF SIDEWALK TO NEAREST CONSTRUCTION JOINT PER CITY STANDARD NO. 203.
2. NEW STREET LIGHT POLE (MAXIMUM 12-IN DIAMETER) SHALL BE INSTALLED IN THE ORIGINAL LOCATION.
3. ENCLOSURE CONTAINING RADIO EQUIPMENT SHALL NOT EXCEED FOUR (4) CUBIC FEET IN SIZE. ONLY ONE VISIBLE ANTENNA PER "SEMI-STEALTH" SITE SHALL BE PERMITTED. ANTENNA IS NOT INCLUDED IN FOUR (4) CUBIC FOOT REQUIREMENT.
4. INSTALL VAULTS IN LOCATION THAT ALLOWS A 2 FT WIDE CLEAR AREA ADJACENT TO THE VAULT TO ALLOW FOR FUTURE CONDUIT INSTALLATIONS OR STREET WORK.
5. PULL-BOX WITH POWER SWITCH AND BREAKER SHALL BE LOCATED NO MORE THAN 20-FT FROM THE BASE OF THE SITE UTILITY POLE. BOX LID SHALL BE ENGRAVED WITH TEXT HEIGHT NO SMALLER THAN 3/4-IN CONTAINING THE FOLLOWING TEXT: "CELL SITE POWER SHUT-OFF SWITCH" AND HAVE THE SITE OWNER NAME, SITE ID, SITE ADDRESS AND EMERGENCY CONTACT PHONE NUMBER.
6. PAINT ANTENNA(S) / EQUIPMENT TO MATCH POLE.
7. WHEN INTERNAL CONDUITS CANNOT BE PROVIDED, MAXIMUM OFFSET FOR RAISER CONDUIT SHALL BE 4-IN.

GIS NOTES:

DIGITAL SUBMITTAL REQUIREMENTS FOR DATA TO BE USED BY THE CITY'S GEOGRAPHICAL INFORMATION SYSTEM (GIS) IN PREPARING EXHIBITS, MAPS, ETC.

1. PROVIDE DATA IN VECTOR FORMAT. EXAMPLES OF SOME ACCEPTABLE FORMATS ARE:
  - AUTOCAD (.DWG OR .DXF)
  - SHAPFILE (.SHP)
2. USE UNDERSCORE OR HYPHENS IN THE FILE NAME, NOT SPACES. PROVIDE A SEPARATE DRAWING FILE FOR EACH INDIVIDUAL SHEET CREATED IN AUTOCAD.
3. DEFINE THE COORDINATE SYSTEM AS NAD 1983 STATE PLANE, CALIFORNIA ZONE 6 (US FEET).
4. FOR AUTOCAD FILES, CREATE ALL DATA ELEMENTS IN MODEL SPACE, ADD LAYOUT ELEMENTS IN LAYOUT SPACE, SAVE THE MODEL IN MODEL SPACE, DO NOT ADD VIEWPORTS TO MODEL SPACE AND EXPLODE THE BLOCKS.
5. PROVIDE DATA FOR ALL CONDUITS, BOXES, NODES, ETC. INSTALLED DURING THE PROJECT. SUBMITTAL SHALL BE FROM "AS-BUILT" DATA, NOT ORIGINAL DESIGNS.

APPROVED:

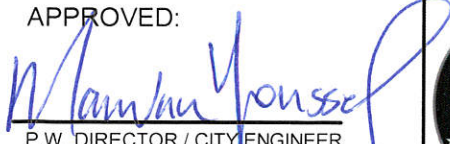
  
P.W. DIRECTOR / CITY ENGINEER  
REVISION DATE: March, 2019



**City of Westminster**

DEPARTMENT OF PUBLIC WORKS

GENERAL NOTES FOR  
SMALL CELL INSTALLATIONS

STANDARD PLAN

**800**

1 OF 6

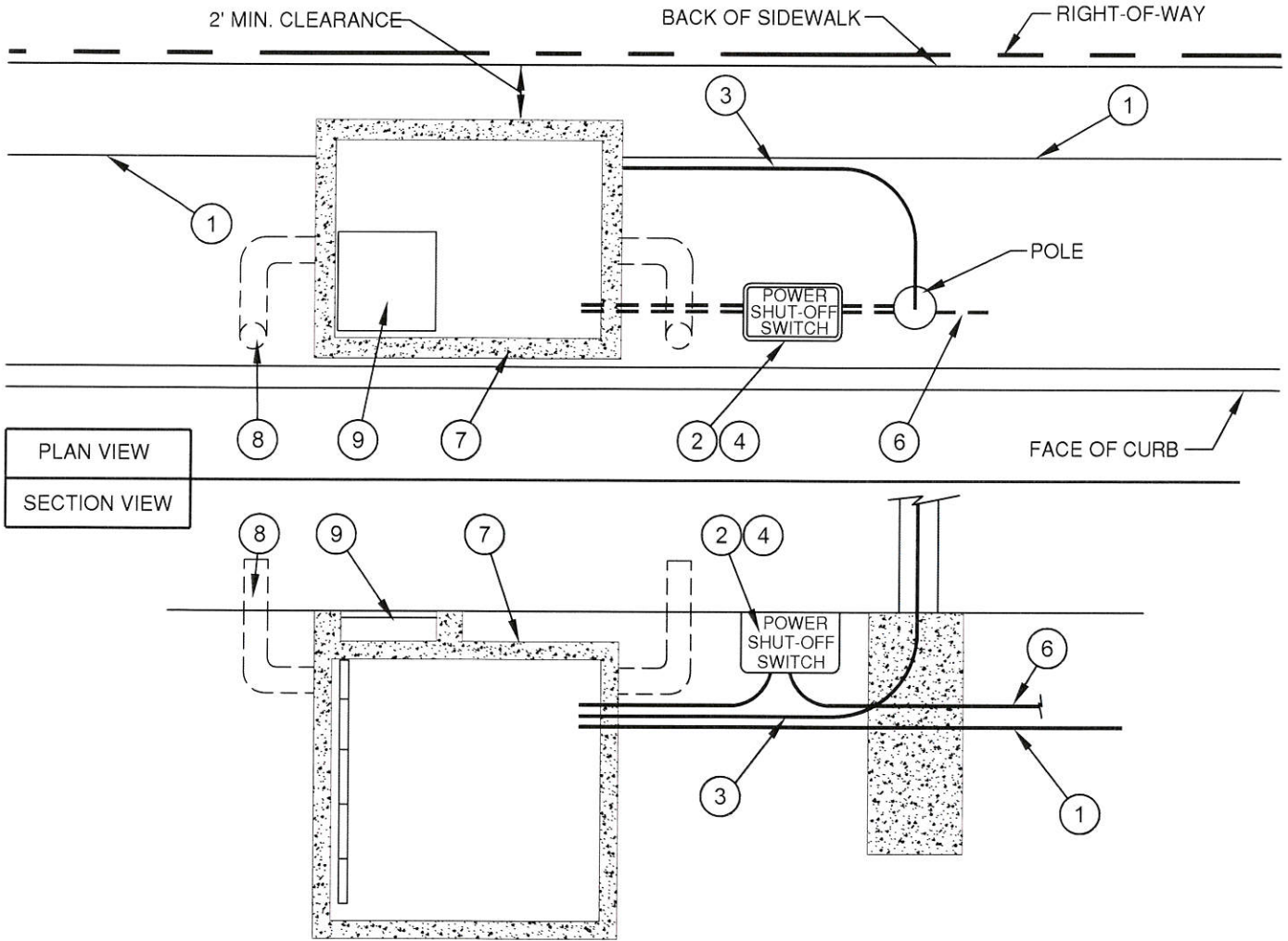

CONSTRUCTION NOTES

- ① COMMUNICATIONS CONDUIT PER SEPARATE ENCROACHMENT PERMIT.
- ② PULL-BOX PER APPLICABLE STANDARDS.
- ③ CONDUIT PER APPLICABLE STANDARDS.
- ④ UNDERGROUND SWITCH AND BREAKER NO MORE THAN 20-FT FROM BASE OF POLE.
- ⑤ INTERNAL CONDUITS REQUIRED FOR STREET LIGHT POLE.
- ⑥ SCE POWER CONDUIT IF POWER SOURCE IS SUPPLIED FROM ADJACENT POLE OR OTHER CIRCUIT.
- ⑦ OLDCASTLE PRECAST VAULT - MODEL MC510 OR APPROVED EQUAL.
- ⑧ VENT AS NEEDED.
- ⑨ ACCESS HATCH PER VAULT MANUFACTURER.
- ⑩ MAX. POLE DIAMETER OF 12" FOR STREET LIGHT POLE

NOTES

-UNDERGROUND INSTALLATION SHALL BE USED FOR SMALL CELL FACILITIES GREATER THAN 4CF IN TOTAL VOLUME.  
 -SEE STANDARD PLAN NO. 800 PG. 1 FOR GENERAL NOTES

APPROVED:

*Mamun Youssef*  
 P.W. DIRECTOR / CITY ENGINEER

REVISION DATE: *March 2019*



**City of Westminster**  
 DEPARTMENT OF PUBLIC WORKS

**SMALL CELL INSTALLATION**  
 CASE 1: EQUIPMENT UNDERGROUND

STANDARD PLAN

**800**

2 OF 6

ANTENNA SHROUD TO MATCH  
COLOR AND STYLE OF POLE.  
MAX. DIAMETER = POLE  
DIAMETER + 4"

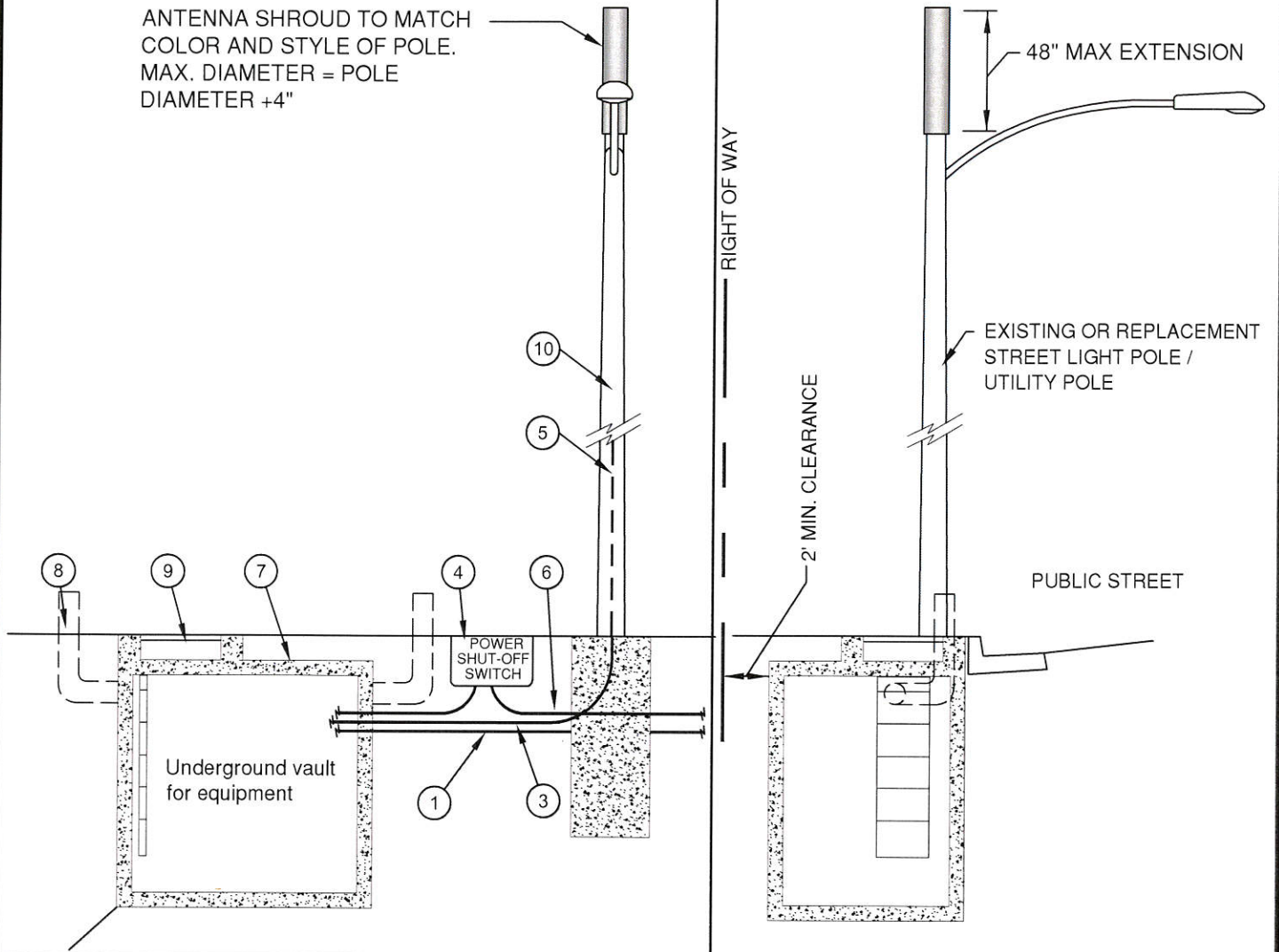

STREET SIDE VIEW

SECTION VIEW

NOTES

- UNDERGROUND INSTALLATION SHALL BE USED FOR SMALL CELL FACILITIES GREATER THAN 4CF IN TOTAL VOLUME.
- SEE STANDARD PLAN NO. 800 PAGE 1 FOR GENERAL NOTES

APPROVED:

*Mamie Youssif*  
P.W. DIRECTOR / CITY ENGINEER  
REVISION DATE: *March, 2019*



**City of Westminster**  
DEPARTMENT OF PUBLIC WORKS

SMALL CELL INSTALLATION  
CASE 1: EQUIPMENT UNDERGROUND

STANDARD PLAN

**800**

3 OF 6

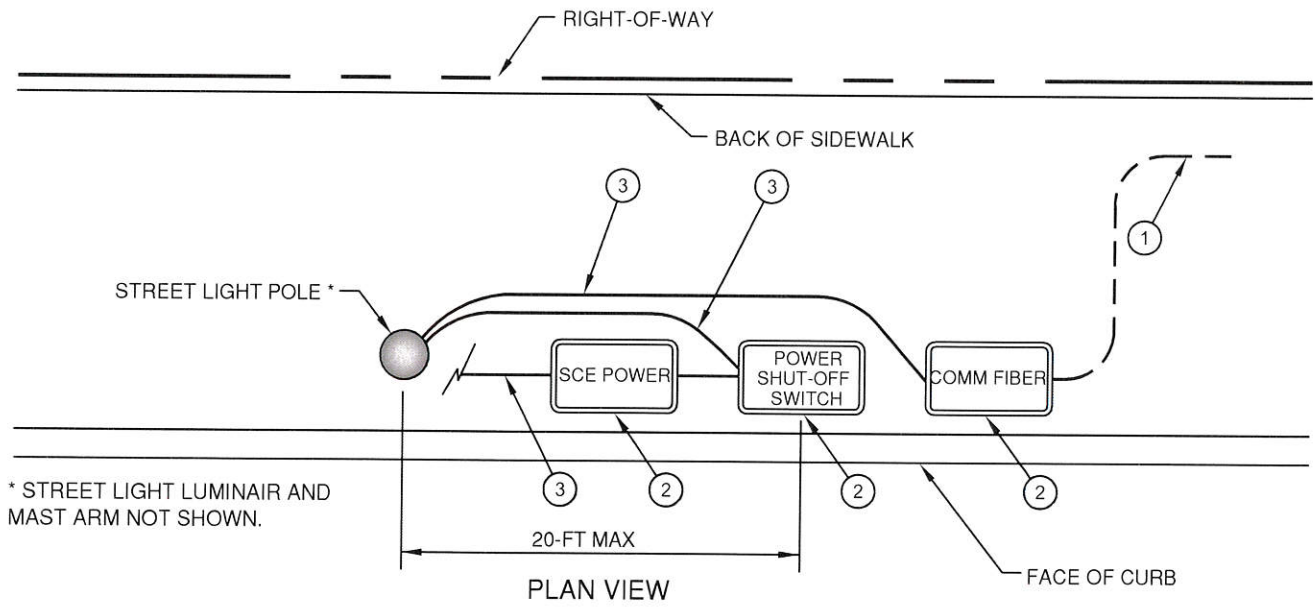

\* STREET LIGHT LUMINAIR AND MAST ARM NOT SHOWN.

ANTENNA SHROUD TO MATCH COLOR AND STYLE OF STREET LIGHT POLE.  
MAX. DIAMETER = POLE DIAMETER + 4"

MAX. LIGHT POLE DIAMETER = 12"

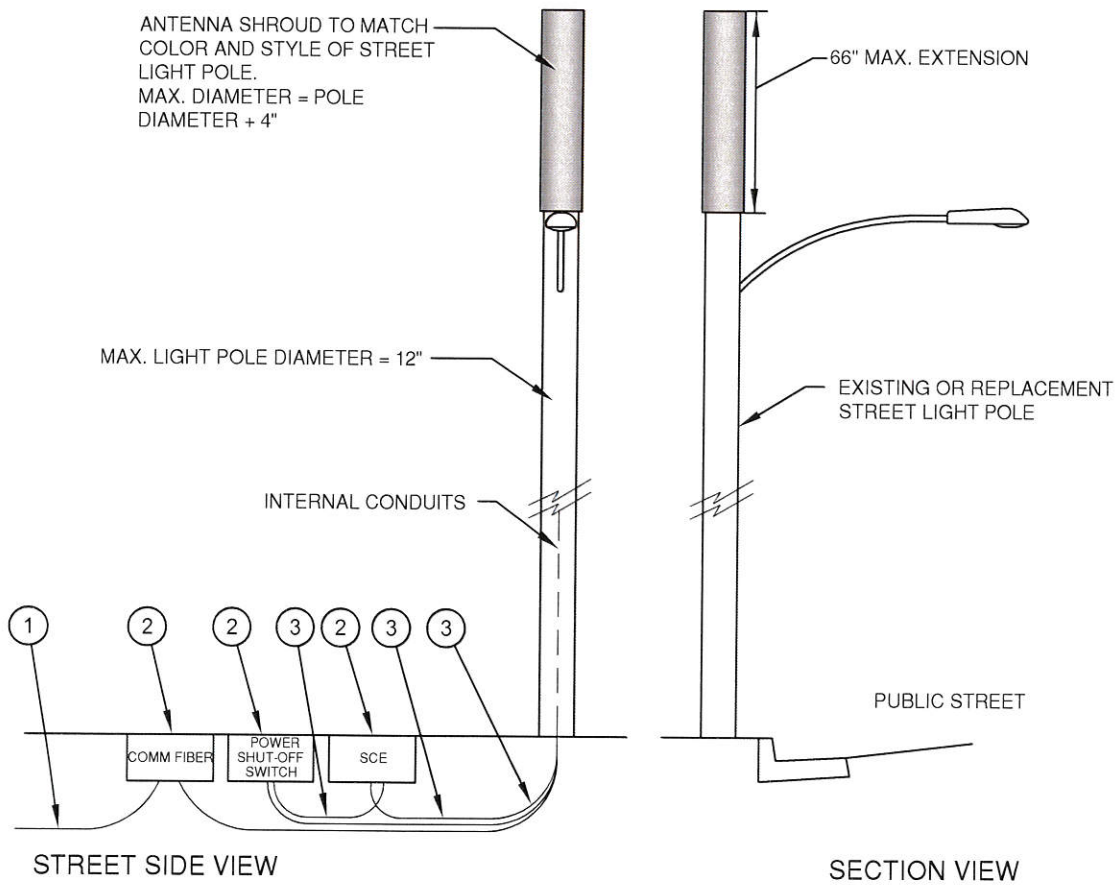

**NOTES**

- ① COMMUNICATIONS CONDUIT PER SEPARATE ENCROACHMENT PERMIT.
- ② PULL-BOX PER APPLICABLE STANDARDS.
- ③ CONDUIT PER APPLICABLE STANDARDS.

**GENERAL NOTES**

-SEE STANDARD PLAN NO. 800 PG. 1 FOR GENERAL NOTES

APPROVED:  
*William Yousef*  
P.W. DIRECTOR / CITY ENGINEER  
REVISION DATE: *March, 2019*



**City of Westminster**  
DEPARTMENT OF PUBLIC WORKS  
**SMALL CELL INSTALLATION**  
**CASE 2: "STEALTH" POLE**

STANDARD PLAN  
**800**  
4 OF 6

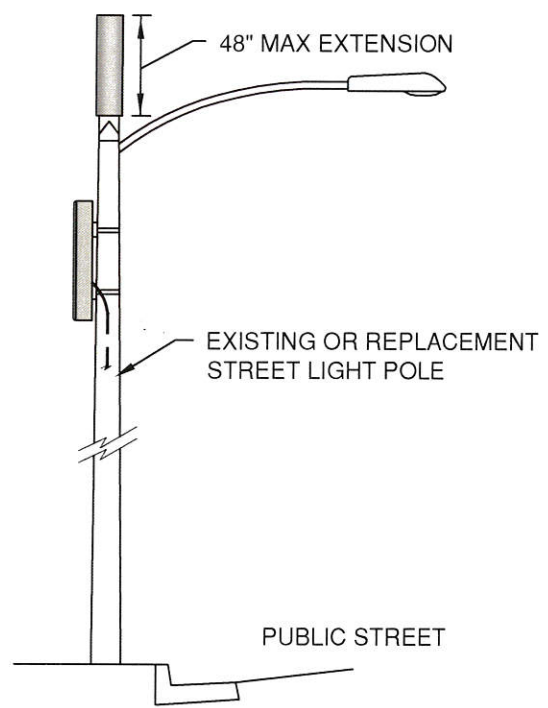
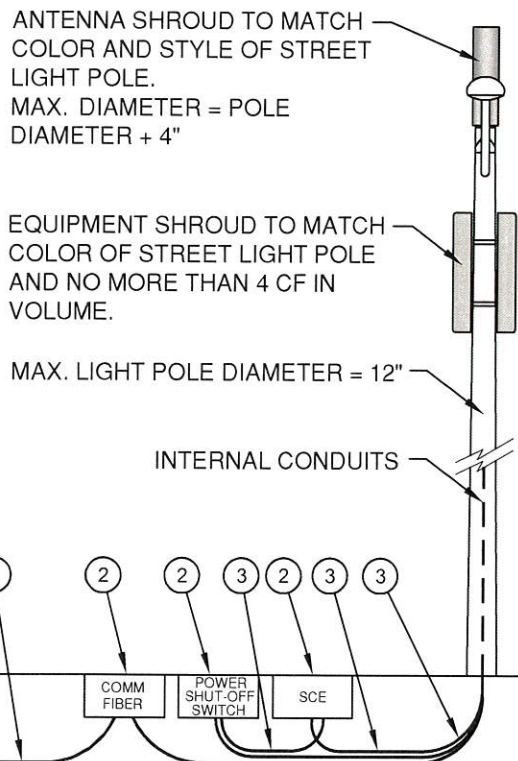
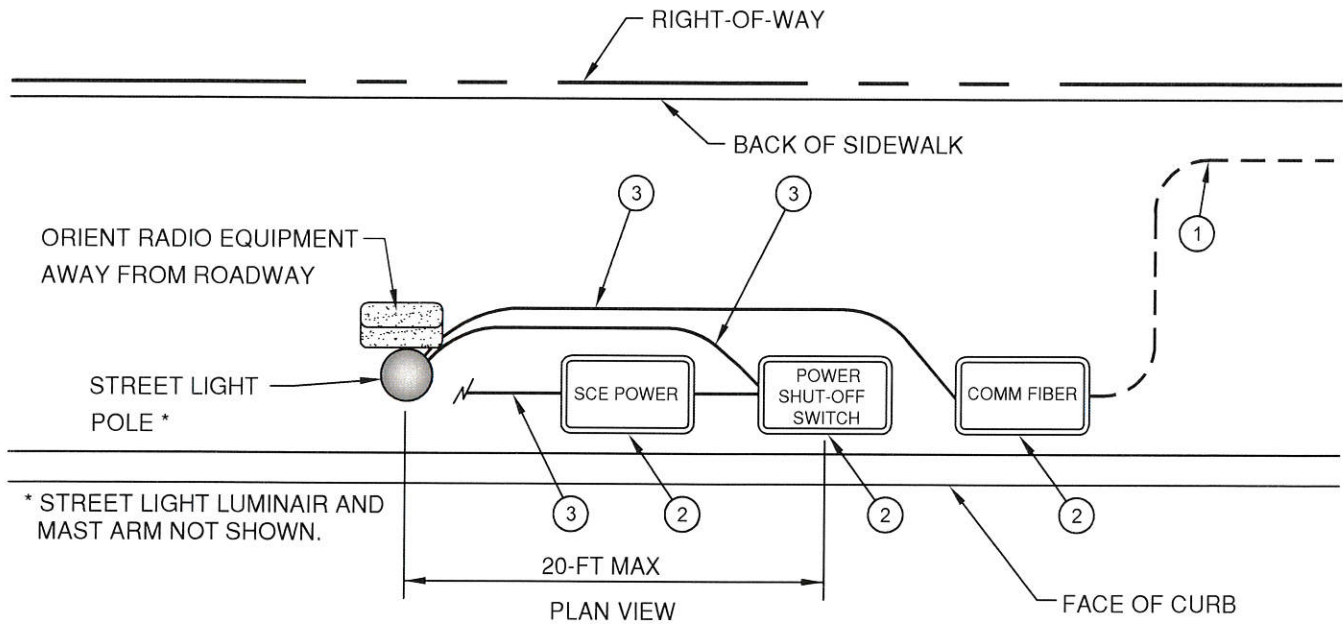

**NOTES**

- ① COMMUNICATIONS CONDUIT PER SEPARATE ENCROACHMENT PERMIT.
- ② PULL-BOX PER APPLICABLE STANDARDS.
- ③ CONDUIT PER APPLICABLE STANDARDS.

**GENERAL NOTES**

-SEE STANDARD PLAN NO. 800 PG. 1 FOR GENERAL NOTES

APPROVED:

*Mariam Youssef*  
 P.W. DIRECTOR / CITY ENGINEER  
 REVISION DATE: *March 2019*



**City of Westminster**  
 DEPARTMENT OF PUBLIC WORKS

**SMALL CELL INSTALLATION  
 CASE 3: "SEMI STEALTH" POLE**

STANDARD PLAN

**800**

5 OF 6

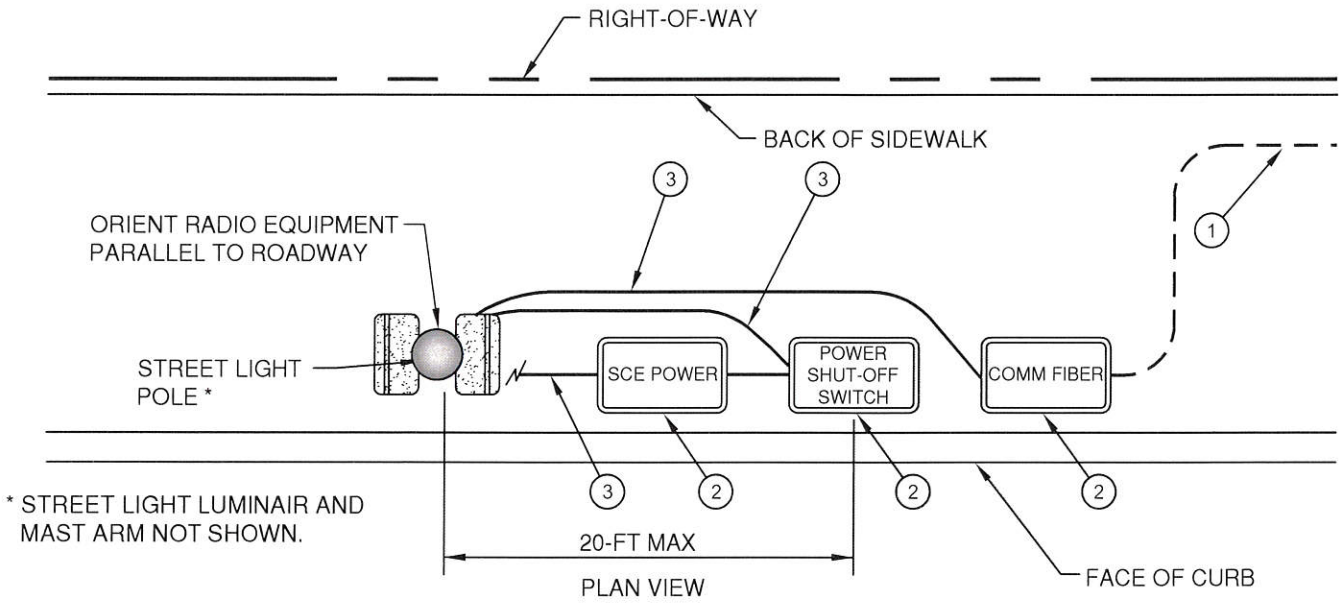

\* STREET LIGHT LUMINAIR AND MAST ARM NOT SHOWN.

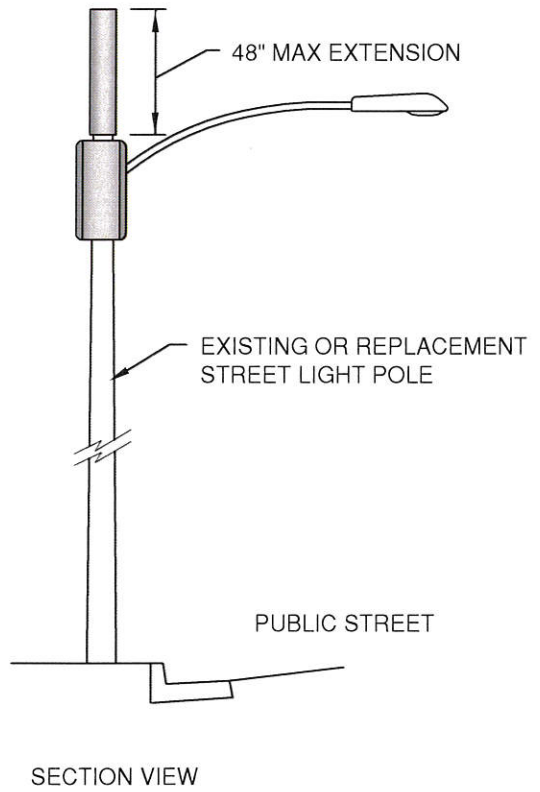
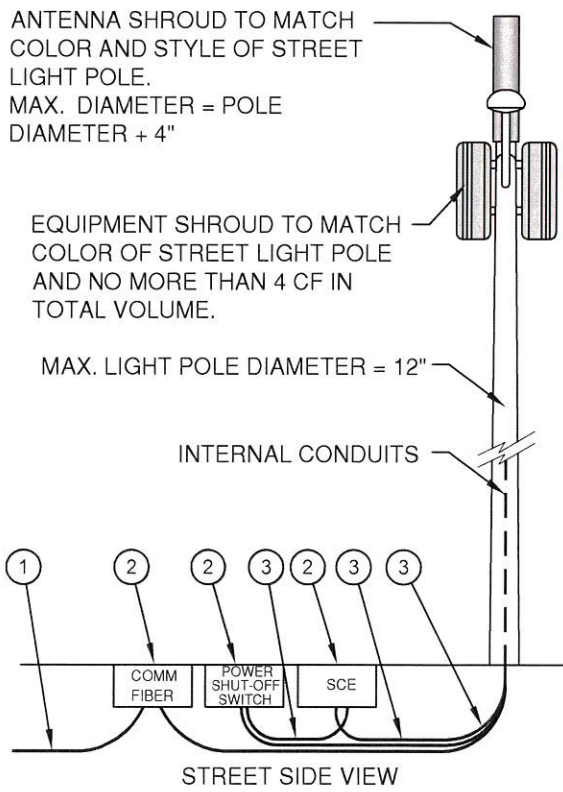

**NOTES**

- ① COMMUNICATIONS CONDUIT PER SEPARATE ENCROACHMENT PERMIT.
- ② PULL-BOX PER APPLICABLE STANDARDS.
- ③ CONDUIT PER APPLICABLE STANDARDS.

**GENERAL NOTES**

-SEE STANDARD PLAN NO. 800 PG. 1 FOR GENERAL NOTES

APPROVED:  
  
 P.W. DIRECTOR / CITY ENGINEER  
 REVISION DATE: March, 2019



<b>City of Westminster</b> DEPARTMENT OF PUBLIC WORKS	
<b>SMALL CELL INSTALLATION</b> <b>CASE 4: "SLEEK" POLE</b>	STANDARD PLAN <b>800</b> 6 OF 6